

THE MINUTES OF THE MEETING OF THE JOINT APPROPRIATIONS  
SUBCOMMITTEE ON NATURAL RESOURCES  
February 6, 1981

The meeting was called to order on February 6, 1981 at 8:00 a.m. in Room 431 of the Capitol Building. Roll call was taken with all members present.

DEPARTMENT OF NATURAL RESOURCES - HEARING

LEO BERRY, ADMINISTRATOR of the Department of Natural Resources, said that the first item on the department's budget is for the forestry division, and the first item relates to the county fire programs. An item by item sheet (EXHIBIT A) was distributed to the subcommittee, also a map that shows the counties involved (EXHIBIT B).

MR. BERRY stated that the map in red shows the 9 counties that wish to come into the county fire program, (individual plans from each 9 counties are attached to the original minutes only - submitted to the Historical Society), There has been a fiscal note prepared to this. It is around \$500,000 a year general funded.

BOB ROBINSON said that in the 1977 session they added a county in the western part of the state. In the 1979 session they added the six counties only if federal funds supported them. If the federal funds dropped off and the Legislative Analyst's recommendation is in accordance with the intent of the committee of the 1979 session, then the counties should not be included in this budget.

RICHARD J. SANDMAN, Chief, Fire Management Bureau, Division of Forestry, said that prior to 1970, the counties shown in yellow on the map were added periodically over the years on general fund monies. The FTE and the outrunning costs were funded by general funds and they worked together with the counties on funding the capital portion of that. They collected 2¢ per acre. It cost more to collect this than it was bringing in.

In 1976 the Legislature formed a interim committee to study state wide structural and wildfire. The outcome was to do away with the assessment from these counties and to use state monies and the counties can spend their money. They put guards on it saying, if the county does not have an agreement with the state and they have a fire problem in the county, the state has to help them or the county has to reimburse all the state's costs.

Secondly, if a county wants to get into the program, they must prepare a plan that states what the county and state will do. In 1978 and 1979 they had an increase in federal monies that was strictly for projects. It saved the state

\$500,000 suppression costs because of one of those projects. In 1980 and 1981 they looked at their budget and wondered where to project that figure. With the six counties coming it was decided that was where to fund it from. Prior, it was all funded from general funds. Funds have dropped off since then.

THE FOLLOWING TESTIMONIES WERE GIVEN:

DUSTY RHOADES, Montana City Volunteer Fire Dept., Clancy, Mt., said that they have about 10,000 acres. They have only a state fire truck, about 200 families, four businesses and a lot of state land that they have an agreement to take care of. They asked for the subcommittee's support. (EXHIBIT C)

DAVE FISHER of the Montana Volunteer Firemen's Association, testified, stating that these firemen work for nothing, so the least the state and county could give them was the tools to work with, and if they do not, someone is going to have a big bill to pick up.

MR. SANDMAN stated that all they are addressing is the wildfire protection. That they are very close to the structural people. He said that in eastern Montana, rather than the state doing the protection themselves, they work with the counties. They fight fires on state lands, and that costs about 4¢ per acre.

GARY BROWN spoke in favor of supporting the program.

ROBERT MILLER, Beaverhead County, said they would like to participate. They have one county that cannot get a fire district, and the state fire department cooperated with this county, thus the state gets service and the county gets service. They therefore ask for the support of this program.

SENATOR SMITH asked if this grant money was used only for fire fighting equipment, and it was said that this grant money was used strictly for equipment used in firefighting.

DOROTHY MURPHY, represented Ed Murphy of the Chief of the Elk Park fire department, a small community where most people work in Butte. The Butte fire department is reluctant to answer fires in this community. They have a willing volunteer fire department.

LORREY LATTIN, Boulder, Mt., expressed his opposition to the cut. They have state school sections. They only have a state truck. Their district is supported by the free holders

in that area and are being taxed separately for this fire truck. If a fire starts on your land and jumps to federal lands you are liable. He asked the subcommittee to think about this in reverse.

JIM MILLER, Whitehall Volunteer fire department, spoke in opposing the cut.

DENNIS BEER, Big Timber Fire Chief, said that they have one fire district which is the entire Sweetgrass County. They are putting in time, money and labor into their county. They have been involved with the state forestry, with grants to build up county equipment in the last three years and have received pumper units for the Sweetgrass County. They have two trucks and they are affiliated with the B.T. fire department. Melville is going to build a fire station and have put up money.

This state program has helped a lot of counties in getting started. He opposes the cut.

OLY OILSTED, County Commissioner of Sweetgrass County, stated the peoples donations and state program is their salvation.

SENATOR BOYLAN referred to a volunteer fire department in Bozeman that watched a fire (home) burn because the people did not pay into that protection.

In answer to the statement, it was said that legally they had a right not to fight the fire, but morally it was wrong. This program and equipment was not for fighting structural fires.

DELBERT BULLOCK, Jefferson County, spoke in opposition of the cut.

FRANK PETORE, from Onasis, Montana, spoke in opposition of cuts.

WILL KISSINGER, Montana City, Mt., stated that this is going to protect state lands too.

DORIS SHEPHERD of Helena, with Montana Association of Counties, stated that this was one state-county system that works and is appreciated by the counties. They are sincere volunteer people .

DICK THRETHEWAY of Butte Silver Bow, spoke opposing the cut.

REPRESENTATIVE STOBIE read a letter from JOHN SHONTZ. Other letters and written testimonies were submitted to the secretary.

NATURAL RESOURCES - HEARING continued.

LEO BERRY, ADMINISTRATOR, introduced members of his Department; GARY BROWN, Acting State Forester, DON UNDERWOOD, JOHN ARMSTRONG, Administrator of Centralized Services and BILL GOSNELL, Administrator of the Energy Division.

MR. BERRY said that the forestry is the main division and they are having trouble with federal funding in Centralized Services.

BOB ROBINSON asked them to address where the federal funds have gone and what is furnished by the state to pick up.

MR. BERRY said that they have that listed in their presentation.

DON UNDERWOOD said the LFA requests funds that are not available, \$288,000 is part of a modified program.

BOB ROBINSON referred to the 0411 fund and explained their position. \$489,575 was available in 1980. If it is continued in 1982 it would be \$588,000, LFA recommendation, depending on revenue income.

There is 156.9 FTEs as a current level.

LFA said money received in 1980 is programmed into FTEs. LEO BERRY said he believed they should break up all of the categories and find their differences and find out what individual analysis are made that will indicate what should be federally funded or state funded.

(SEE EXHIBIT A) presented by DICK SANDMAN. He stated that since 1924, federal money has assisted - Number 2.

It was suggested to fund the fire program from the general fund and when the money comes in to put it back into the general fund. A chart that was given to the subcommittee for review indicated that fire is high in July.

Number 3 - COMMUNICATION POOL: The return of the mentioned FTE was authorized, but no money was put in for it.

Number 4 - HAZARD REDUCTION PROGRAM: Regarding 1.5 FTEs, inspectors, earmarked funds. Note that TSI and the Brush account has the same problems as does the Hazards as far as emergency.

JIM WILLIAMS BUDGET ANALYST, commented that the 148 base is the LFA base.

Number 5 - NURSERY OPERATON: The operation is in Missoula. The LFA would not put any modified into here, in other words, an expansion of the existing program. Seedlings will go to grain farmers and ranchers for shelter belts.

Number 6 - OPERATIONS EXPENSES: They believe that the operating expenses are low.

BOB ROBINSON said the Governor's office nor the LFA fully funded this because of vacancy savings.

Number 7 - AIRCRAFT REPAIRS: This shows divisions requests. (Breakdown in Exhibit A, page 2.)

Regarding helicopters, they do have 2 helicopters. They were free military aircrafts and they have been fighting fires with them. According to studies, they have saved the following amounts by using the helicopters.

1979	suppression cost	\$296,000
1980	suppression cost	\$118,000

They saved \$68,000 on one fire alone. It was noted that to contract a helicopter would cost \$120,000 a year.

The FTE is on the tanker crews being trained to operate under the helitac crew.

Number 8, refers to equipment and operation. Additional money should be included in equipment under some of the other items talked about.

REPRESENTATIVE MANUEL stated that some of this equipment is so old that parts are even impossible to get.

DICK SANDMAN stated that where some items are existing, they do have an income in some areas they are not allowed to spend.

REPRESENTATIVE STOBIE suggested that they look into contracting work out.

Number 9 - URBAN FORESTRY: Urban forestry handles decisions in towns and he works with the cities and towns to control diseases in trees. This program is in the Agriculture Department through Urban Forestry grants.

Number 10 - EXPANDED TIMBER SALES. General fund money have increase sales that goes into School Foundation Account.

THE MINUTES OF THE MEETING OF THE JOINT APPROPRIATIONS Page 6  
SUBCOMMITTEE ON NATURAL RESOURCES  
February 6, 1981

Number 11 - TSI AND BRUSH REMOVAL. If it is not approved,  
this program will be reduced.

LEO BERRY stated that this summerizes FORESTRY.

The meeting adjourned at 10:45 a.m.

  
\_\_\_\_\_  
CHRIS STOBIE, CHAIRMAN

lmw

## Forestry Division

1. The Legislative Fiscal Analyst (LFA) deleted 8.92 FTE from the current level budget. Those consist of 2 foresters, one clerk, 4 mechanics, a part-time pilot and 7 seasonal firefighters (one of these was a lookout). These were started on federal funds, in fiscal year '80. We received approximately \$70,000 less and \$243,000 in '81 than anticipated. In 1980 we made up \$84,000 out of other funds, in '81 we are eating that amount. Through this method 6 counties were added to the program. The method used to add these counties was consistent with the mandates and directions of the Legislature. The problem being that the agency doesn't know until 6-8 months into the fiscal year at what level we will be federally funded. Without these 8.92 positions we will have to drop the six counties and general fund fire suppression costs will increase.
2. Funding Sources. Federal and earmarked funds are overestimated in the LFA budget thus reducing the current level general fund. We are short \$961,949 in '82 and \$1,190,601 in '83. We would like to work out these differences with the LFA.
3. Several years ago the legislature formed a communications pool and transferred 1 FTE from DNRC to DCA. The pool has disbanded and we request that the FTE be transferred back along with necessary funding. The position shows in current level services in Governor Judge's budget.
4. Hazard Reduction Program. This involves 1.5 FTE that were added by budget amendment from earmarked funds to inspect logging operations to reduce fire hazards. These positions show in the current level positions in Governor Judge's budget.
5. Nursery Operation: The 1979-80 legislature approved the construction of a greenhouse system and cooler building to grow containerized seedlings. This project is being completed this Spring and we request two additional FTE's. Funding will come from carryover monies from our bareroot operation and money generated from the sale of trees next Spring.
6. Operating Expenses. We believe that the general fund operating expenses are short by \$120,299 in '82 and \$124,666 in '83. The LFA projections are low because the base utilized was unrealistically low and there are differences in inflation factors. Operating expenses were cut in 1980 in order to make up projected vacancy savings that did not materialize. The additional requested monies would be spread in contracted services, supplies and materials (gas), travel, repair and maintenance and other expenses.

7. Aircraft repairs. Aircraft repairs do not occur annually at a constant level due to the number of flying hours experienced each summer. FY 80 expenditures do not show repairs necessary to aircraft during the next biennium. This amounts to general fund dollars of \$63,000 in '82 and \$6,300 in '83. This is itemized as follows:

- a) Replace Cessna 182 Engine - \$8,000
- b) Replace Cessna 185 Engine - \$10,000
- c) Replace Rotor Blades on Helicopter in '82 - \$25,000
- d) Replace Rotor Blades etc. on Ranger in '82 - \$20,000
- e) Replace Sleeve Assembly on Huey in '83 - \$6,300

8. Also, we would like to take exception to capital purchases. Historically, the capital equipment budget in all division programs has been far too low to allow for proper replacement schedules.

The Division of Forestry operates and maintains a fleet of 330 motorized vehicles, which include 113 county vehicles. In addition to this, we have 2 graders, 4 dozers and miscellaneous other heavy equipment.

Some of this equipment dates back to 1941 and 1942 vintage. A major item that needs replacing is an Austin-Weston Grader. It was a piece of used equipment when we got it in 1964.

Operating vehicles in this condition not only endangers, limb and property in fire suppression activities, but results in considerable high maintenance cost and costs crew time.

9. Urban Forestry. We request 1.5 FTE's to conduct urban forestry programs with federal funding.

This program provides technical assistance, training, and funding to local governments in urban tree planning, maintenance and improvement.

Demonstrations and training schools are sponsored for city forestry department personnel, cemetery personnel, tree services, land developers and others responsible for maintenance of the community trees.

10. Expanded Timber Sales. We request 6 FTE's to expand timber sales on school trust lands which generates revenues for public education. This program will allow us to increase sales from approximately 25 million board feet to 30 million board feet. This request is 5.5 FTE's lower than that submitted by Governor Judge.

11. TSI and Brush Removal. We request 13.60 FTE's from earmarked funds from timber sale harvests. This program relates to the increased sale program mentioned above. If that program is not approved this request would be significantly reduced.



36 Tankers & Tool Units. Train 534  
 4 Million Acres  
 2 1/2 \$/Ac. - 1st 2 yrs.  
 2 \$+/Ac - 3rd yr

1.0 Tankers & Tool Units, 1 train 800  
 Equip. value 1.3 million  
 1 1/2 Million Ac. (1.1 million State)  
 4 \$/Ac. - 1st 2 yrs.  
 2 1/2 \$/Ac - 3rd year.

MONTANA

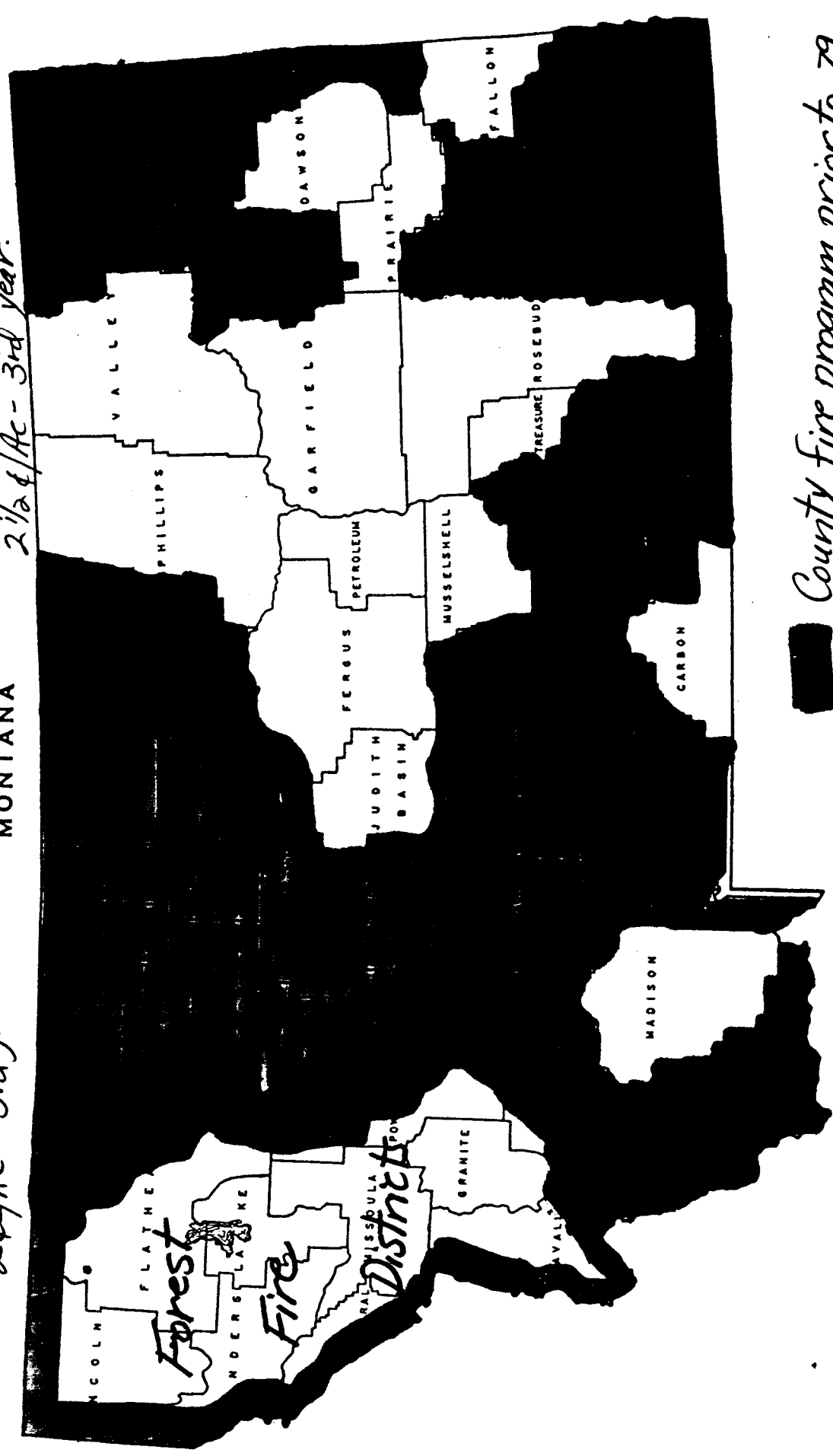

- County fire program prior to 79.
- Counties added 79 & 80.
- Counties requesting entry.

No. 1050 — County Outline Map  
 STATE PUBLISHING COMPANY  
 Helena  
 80 Pads · E · WY



B (C)

NAME DUSTY RHOADES BILL No. \_\_\_\_\_  
 ADDRESS Star Rt Box 1576 Clancy DATE 2-6-41  
 WHOM DO YOU REPRESENT Mt 'city' Vol fire dept  
 SUPPORT \_\_\_\_\_ OPPOSE \_\_\_\_\_ AMEND \_\_\_\_\_

PLEASE LEAVE PREPARED STATEMENT WITH SECRETARY.

Comments:

we feel the money supporting this program  
 is some of the best spent money  
 that comes from the tax payers.

28,000,000

County  
Coop. Program  
26 Co's - 2¢/Ac.

3,400,000

50¢/Ac.

3,200

3,000,000

2,800

2,600

2,400

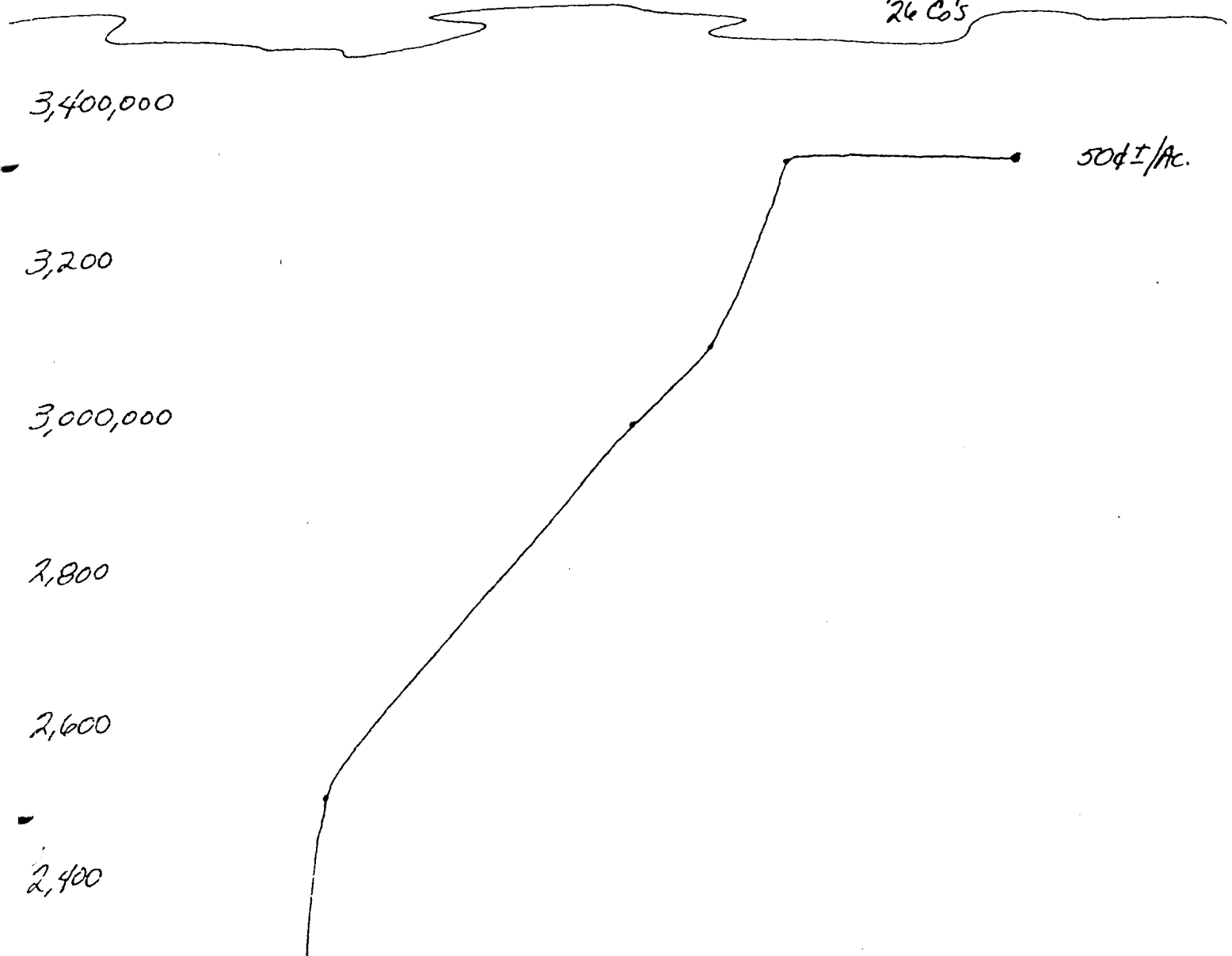

I am representing Ed Murphy, firecheif of the Elk Park Volunteer Fire Dert., A small ranching community where there are many people living, but working in Butte. We are located 10 miles north of Butte on I 15.

Two years ago we heard about the State aid in establishing a fire district, and help with lending equipment, in return for us to fight any fires on State owned ground in our area. We then with a tremendous amount of help from Tim Murphy of the State Forest Dept. formed our department with a revamped military fire truck and from other equipment he has made available to us.

We had a few fires usually small ones , but two which could have been serious. The Butte Fire Dept. is reluctant to ansewer calls in our area because we are in Jefferson County and there are legal set backs for them. With our own Fire Dept. we are able to establish a mutual agreement with them which enables them to help us, should the fire be greater than our capacity to handle it.

Without the aid of the DNRC our fire department would have been impossable, as we would never have been able to get a fire truck to start with. Now we hope to be able to buy one in the future with some of the money we can receive.

We have moved a building onto some land where our old school house is. The land was given to us by the school district and we use the building to house the truck and equinment we have. The members have taken training and we have already put out a few fires which would have costt property owners alot. One was a barn near a house. Also two fires in the Boulder Valley we helped with. So in effect I'm saying I hope you will continue funding these projects , as I'm sure we are not the only community who have benifited along with the fact that the State does not have to dipatch a crew to every small grass fire or timber fire under their jurisdiction which saves money also. These fires may be stopped sooner as

he local men can be on the scene quicker as a rule and hold it down until more help arrives.

Thank you very much

Edward Murphy

Feb. 5, 1981  
Boulder, Montana

TO WHOM IT MAY CONCERN:

Several years ago, the Montana legislature passed a law creating rural fire districts statewide. The organization and funding of these local districts was picked up almost entirely by the taxpayers of those areas, in a majority of the cases adding yet another tax to the rural families that were and are already sorely overburdened, and pay more than their fair share. To alleviate some of the burden we were allowed access to surplus property and entitled to some matching funds that were funneled through the state division of forestry. As far as the directors and members of the BOULDER RURAL VOLUNTEER FIRE DEPARTMENT are concerned, this aid, both financial and in-kind, has been instrumental in our organization being successful.

There are several hundred acres of state lands that lie within our area of protection, and several thousand acres of national forest lands that we are bound to make at least the initial attack on in the event of a fire. If you take away the funding that has enabled us to have a state truck placed with us, and the direct grant-type funds, we will be left with the added responsibility of protecting the aforementioned lands and the costs will have to be borne entirely by the taxpayers of the district. This kind of thinking is damned unfair especially when it was you people that legislated us into this position in the first place. We would urge you to recommend against this particular cut. Thank you.

Regards,

*Boulder Rural Fire Dept,*  
*Larry Latta Sec-Treas*  
*Barton R. Cooper Chief*  
*Tom Tanner DIRECTOR*  
*Tom Murphy Director*  
*Jim Stal Pres Bd of directors*

COMMISSIONERS:

JEFFERSON COUNTY

JOANNE P. McFARLANE  
County Clerk and Recorder

CARLA MATLACK  
Deputy

cent M. Capp, Chairman, Whitehall  
Leslie J. Sodorff, Clancy  
Delbert M. Bullock, Basin

CLERK and RECORDER

Boulder, Montana 59632

February 4, 1981

TO WHOM IT MAY CONCERN:

The Board of County Commissioners of Jefferson County are of the understanding that Jefferson County is one of the six (6) counties who stand to lose State-Federal Cooperative Funding and use of Federal Surplus property which is under the supervision of the State Department of Natural Resources, Forestry Division.

Jefferson County has (four) 4 Rural Fire Departments whose existance depends upon the current use of these cooperative agreements. These Rural Fire Departments are in large part responsible for the control of fires on State and Federal Forest land. Without this agreement, it will be physically impossible for these rural fire departments to function effectively. We therefore request that funding for these Jefferson County Rural Fire Districts be from the State General Fund as are the other rural fire district in the State.

Yours truly;

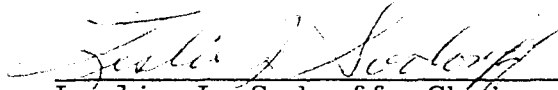
  
\_\_\_\_\_  
Leslie J. Sodorff, Chairman  
Board of County Commissioners

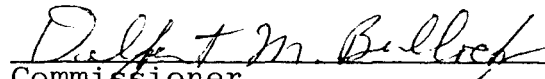
  
\_\_\_\_\_  
Commissioner

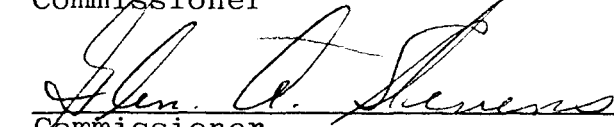
  
\_\_\_\_\_  
Commissioner

LJS/jj

# Fire Program

①

## Income

## State Accounts

## Expenditures

General Fund

Fire Supplementals

Assessments  
Private

Rural Fire Prev. & Cont.  
Federal

Contracts  
USFS  
BLM

Rural Comm. Fire Prot.

Disaster Asst.  
FEMA

Billable Fires

General  
Fund  
01100

F&P  
Revenue  
04419

Salaries  
Wages  
Benefits

Contr. Serv.  
Supp. & Mat.  
Comm. & Tr.  
Travel  
Rent  
Utilities  
Rep. & Mnt.  
Other

Capital Equip.  
Capital Lands

State General  
Fund



# Fire Protection

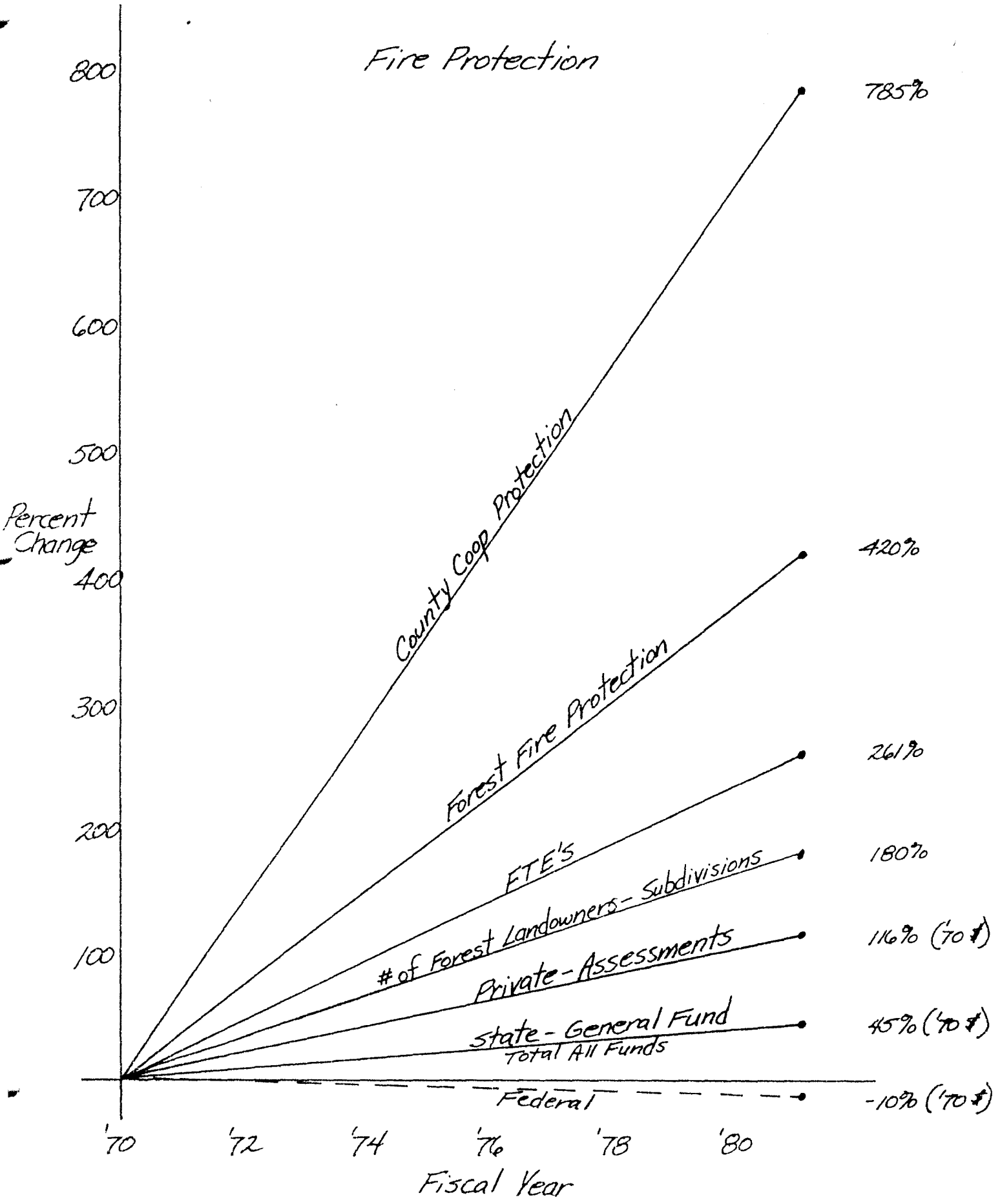

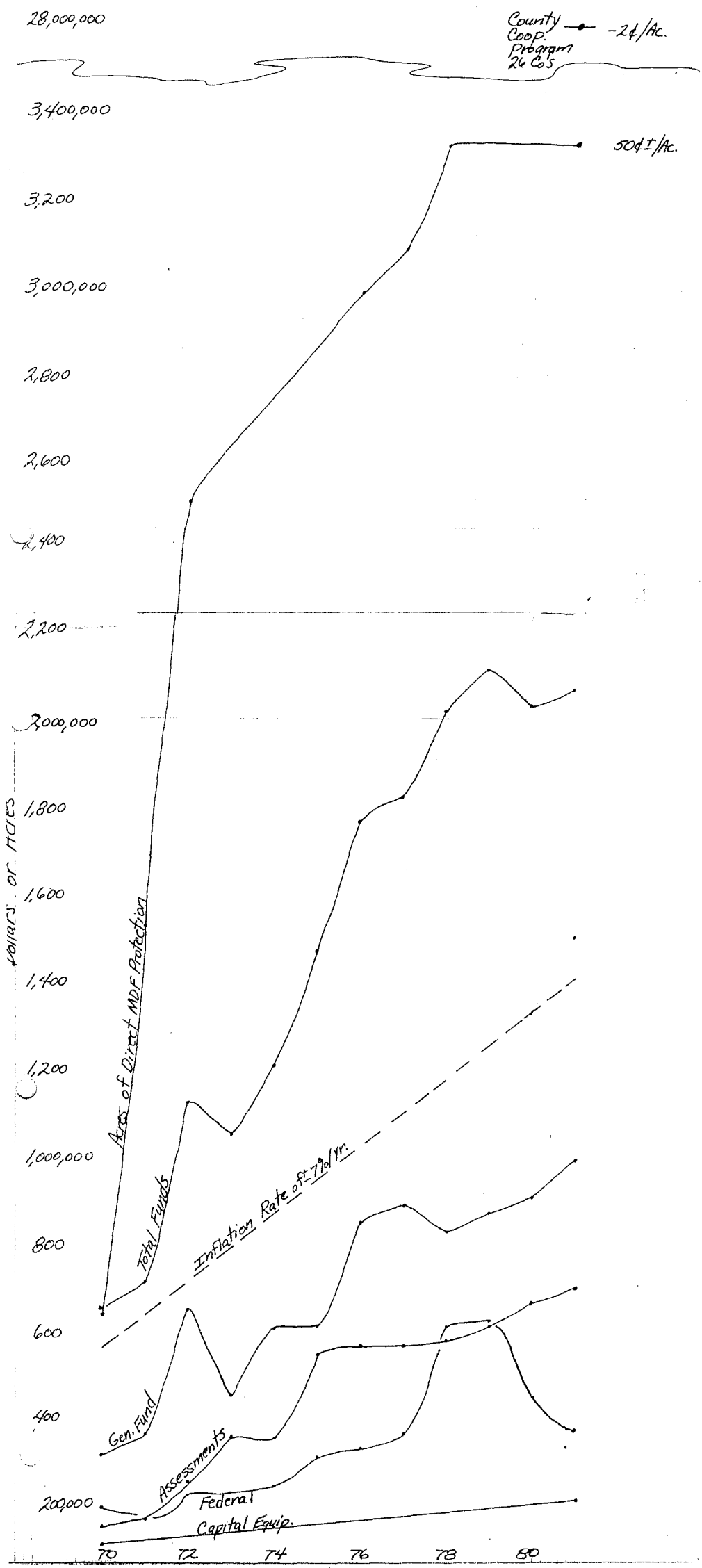

CROSS SECTION - 10 SQUARES TO INCH

Fire Program Funding

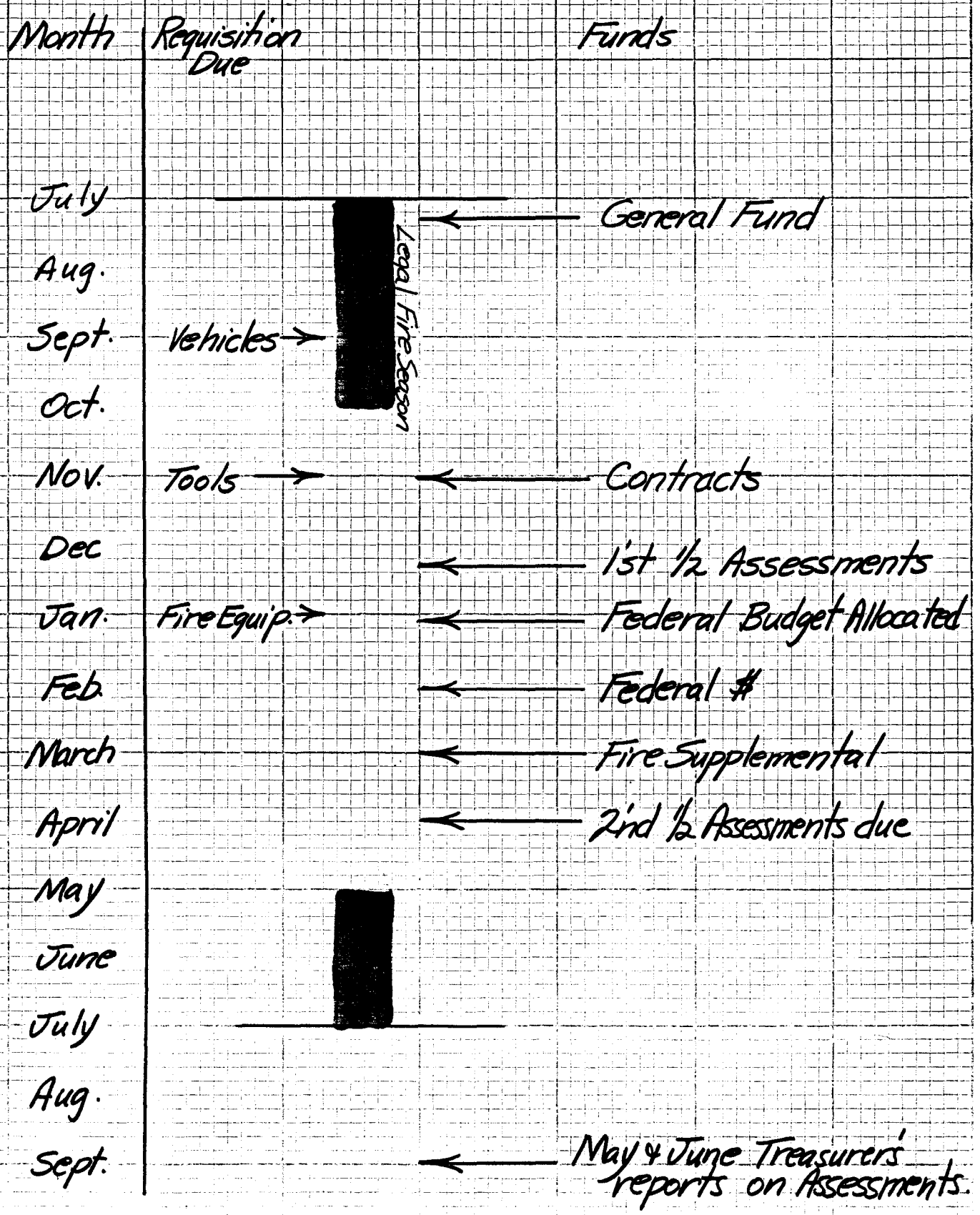

CROSS SECTION - 10 SQUARES TO INCH

### Fire Program - Major Funds.

Dollars

\$ 2.50

2.13

2.00

1.50

1.28

1.00

50¢

General Fund

Assessments

Federal

1.43

1.00

54¢

'70

'72

'74

'76

'78

'80-81

Fiscal Years

CROSS SECTION - 10 SQUARES TO INCH

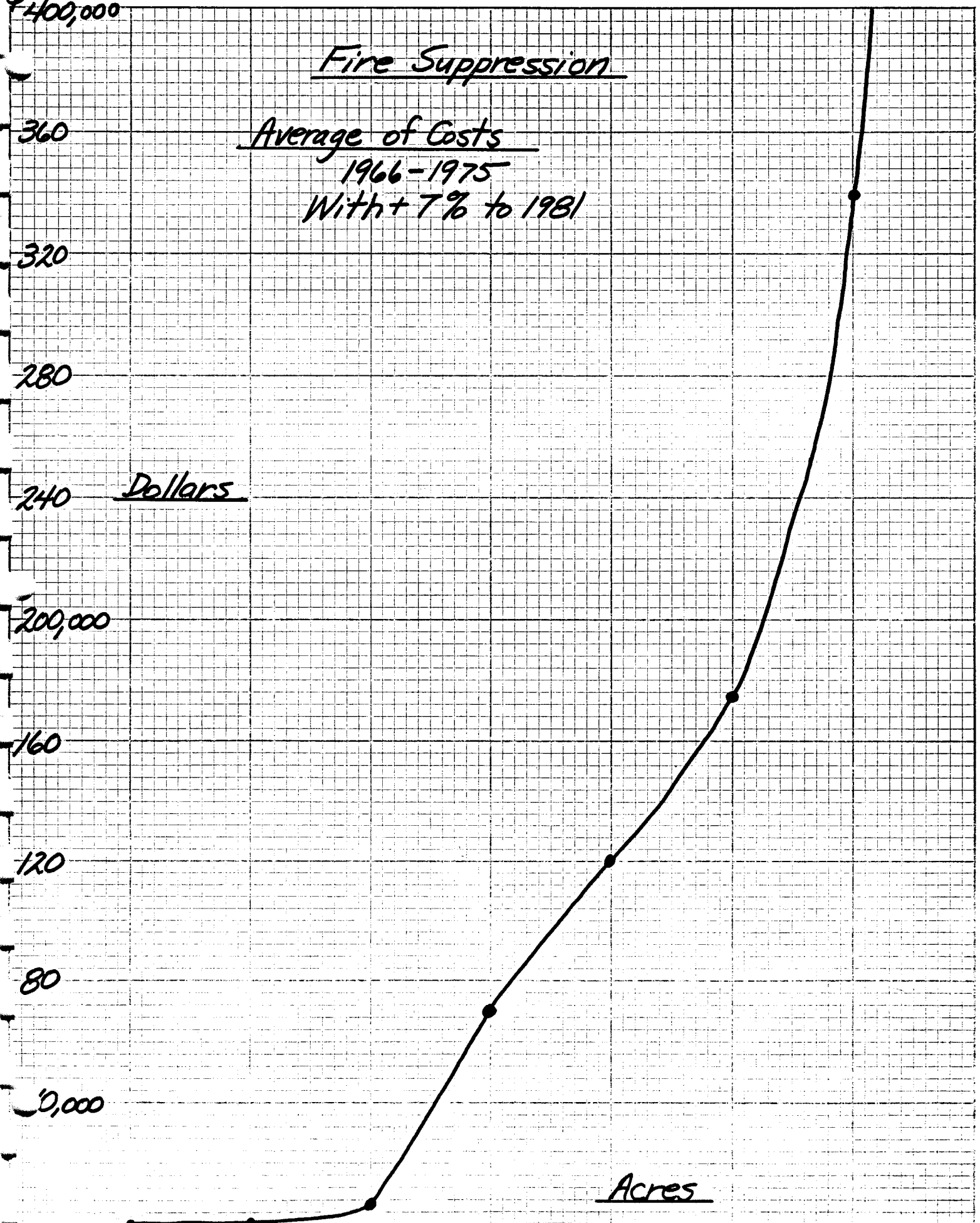

⑦

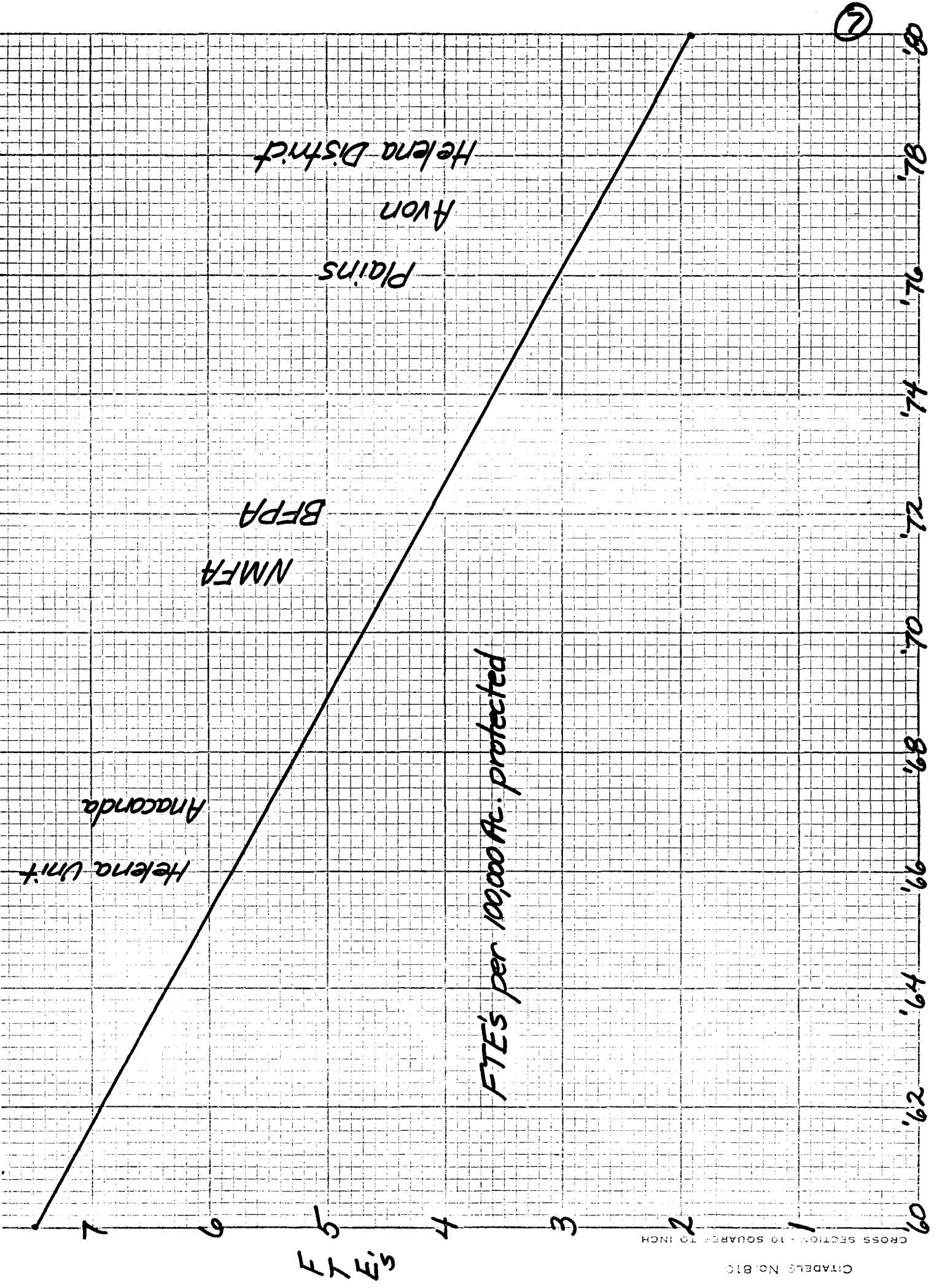

CROSS SECTION - 10 SQUARE 10 INCH

CITADEL No. 810

FTE's

FTE's per 100,000 sq. ft. protected

Helena Unit

Anacanda

NMFA

BPPA

Plains

Avon

Helena District

THE MOST BASIC CONCLUSION REACHED BY THE COMMITTEE IS THAT DIVERSIFIED USES OF STATE LAND, PARTICULARLY RECREATIONAL USE, WILL BECOME PRACTICAL AND ADVISABLE ONLY WHEN THE STATE OF MONTANA ASSUMES A DIRECT OBLIGATION IN THE MANAGEMENT AND PROTECTION OF THESE LANDS. THE RECOMMENDATIONS OF THE COMMITTEE FOCUS AND HINGE ON THIS POINT.

THE COMMITTEE RECOMMENDS THAT THE STATE OF MONTANA ASSUME THE DIRECT RESPONSIBILITY FOR THE PROTECTION OF ALL STATE-OWNED LANDS FROM DESTRUCTIVE FIRES STARTED BY ANY CAUSE. THE COMMITTEE FURTHER RECOMMENDS THAT SUCH FIRE PROTECTION BE PROVIDED THROUGH AN EXPANSION OF THE EXISTING FACILITIES OF THE BOARD OF FORESTRY, COMPLEMENTED BY A COOPERATIVE PROGRAM WITH THE VARIOUS COUNTIES, SOIL AND WATER CONSERVATION DISTRICTS, RURAL FIRE DEPARTMENTS AND OTHER AGENCIES OR GROUPS.

(DIVERSIFIED USES OF STATE LANDS COMMITTEE REPORT--1968)

THE MANAGEMENT OF STATE-OWNED GRAZING AND AGRICULTURAL LANDS HAS RECEIVED A DIFFERENT FORM OF MANAGEMENT. THESE LANDS, EXCEPT IN RARE ISOLATED CASES, DO NOT RECEIVE ADEQUATE ORGANIZED PROTECTION FROM FIRE. THE LEASE REQUIRES THE LESSEE TO PROVIDE FIRE PROTECTION, YET FEW LESSEES HAVE THE TRAINING OR FACILITIES TO PROVIDE ADEQUATE PROTECTION. THE LESSEE STRONGLY FEELS THIS RESPONSIBILITY. HE IS FULLY AWARE THAT THE RECREATING PUBLIC, THROUGH CARELESSNESS, CAN JEOPARDIZE NOT ONLY HIS CROP, HIS PERSONAL PROPERTY, BUT THE NATURAL RESOURCE, AND CONSEQUENTLY, SOME LESSEES REFUSE THE PUBLIC ENTRY.

THE COMMITTEE RECOGNIZES THAT IT WOULD BE IMPRACTICAL AND UNDESIRABLE TO IMPLEMENT ALL OF ITS RECOMMENDATIONS DURING A SINGLE SESSION OF THE LEGISLATURE. AS AN EXAMPLE, THE IMPLEMENTATION OF STATE-WIDE FIRE PROTECTION ALONE WOULD TAKE 6 TO 8 YEARS TO IMPLEMENT IN AN ORDERLY AND DELIBERATE MANNER. HOWEVER, THE COMMITTEE SUGGESTS THAT SIGNIFICANT ACTION CAN BE INITIATED IN PRACTICALLY ALL RECOMMENDATIONS.



*Fire Tankers - Co. Coop. program*  
MONTANA

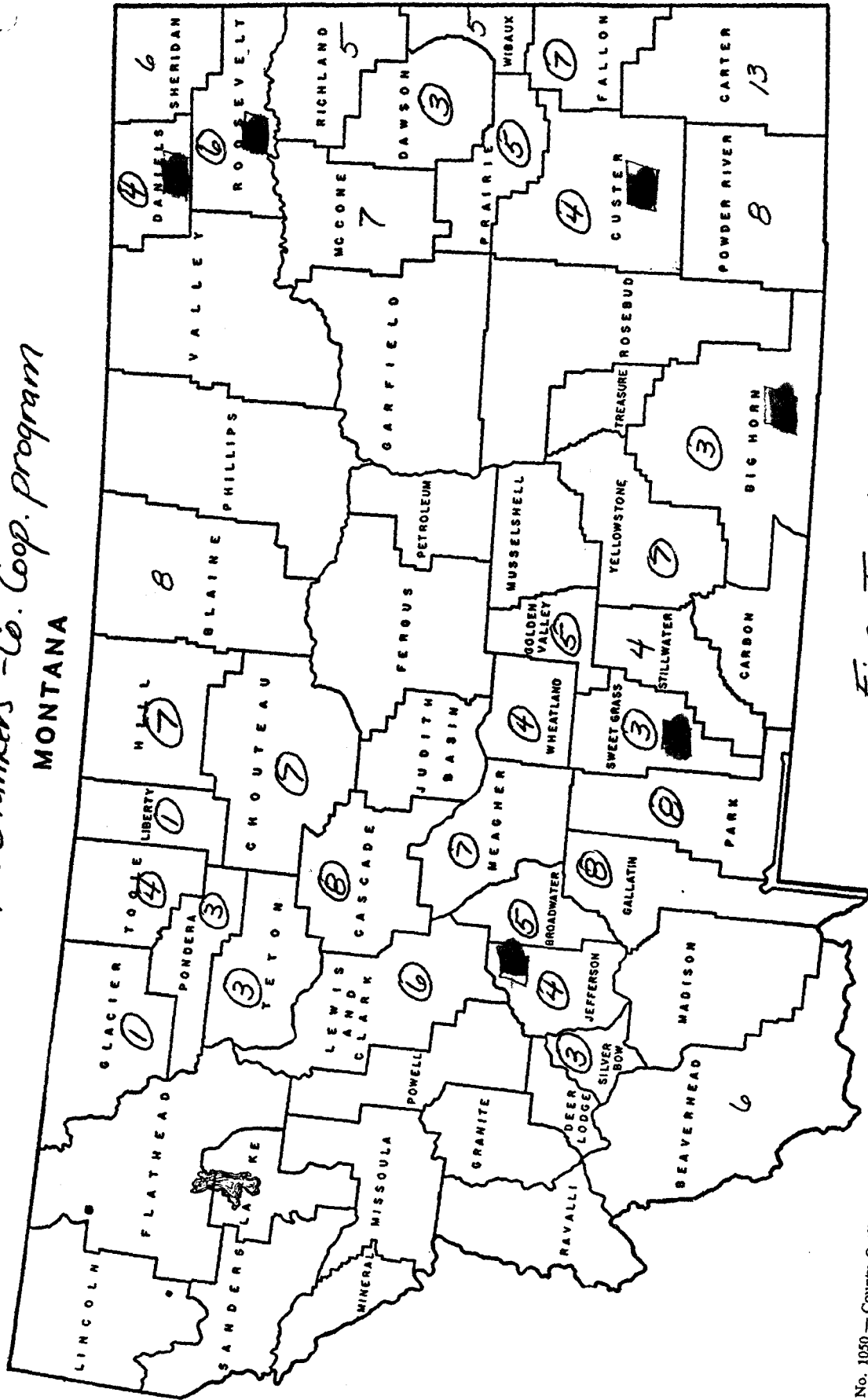

*Fire Tankers*

126 delivered  
Complete 1979 Additions  
59 Proposed 1981 Additions

12

Co. Fire County	Co. Funds & Volunteer Contributions	State Funding	# of Tankers	# of Tool Units	Train Volunteers
Beaverhead	'82 \$ 29,667	\$ 49,490	3	3	58
	'83 <u>32,283</u>	<u>45,759</u>	3	3	60
	'84 34,507	26,023	-	-	60
Blaine	'82 49,066	41,194	5	3	92
	'83 <u>57,762</u>	<u>43,474</u>	4	2	102
	'84 63,027	23,283	-	-	117
Carter	'82 17,539	71,885	6	5	60
	'83 <u>20,374</u>	<u>84,470</u>	7	5	70
	'84 22,231	41,672	-	-	20
McCone	'82 21,936	59,673	4	3	58
	'83 <u>23,410</u>	<u>53,891</u>	3	3	73
	'84 30,706	34,962	-	-	83
Powder River	'82 64,196	58,124	4	3	50
	'83 <u>69,860</u>	<u>61,976</u>	4	3	70
	'84 77,570	36,566	-	-	80
Richland	'82 69,488	56,294	3	3	130
	'83 <u>77,653</u>	<u>55,743</u>	2	2	130
	'84 87,319	34,091	-	-	130
Sheridan	'82 35,928	58,825	5	5	115
	'83 <u>42,267</u>	<u>55,373</u>	3	3	115
	'84 47,692	35,109	-	-	115
Stillwater	'82 59,394	38,376	2	4	100
	'83 <u>65,570</u>	<u>36,400</u>	2	4	115
	'84 72,184	21,390	-	-	125
Taux	'82 23,460	50,764	2	3	30
	'83 <u>26,022</u>	<u>46,686</u>	1	3	30
	'84 28,528	33,323	-	-	30
		Av. 2484,348/84: 1824	34/29/Total	28/32/Total	693/765/Total

TO: RICHARD J. SANDMAN, Chief, Fire Management Bureau, Division of Forestry

FROM: JOSEPH W. GASVODA, Supervisor, Rural Fire Assistance Section,  
Fire Management Bureau

- SUBJECT:
- I. LOCATION OF EQUIPMENT SUPPLIED BY THE DIVISION OF FORESTRY TO COUNTIES AS PROVIDED UNDER THE COOPERATIVE FIRE CONTROL AGREEMENT
  - II. EXCESS PROPERTY IN USE BY THE MISSOULA RURAL FIRE DISTRICT UNDER SEPARATE AGREEMENT
  - III. EXCESS PROPERTY IN USE BY EAST MISSOULA FIRE DEPARTMENT UNDER SEPARATE AGREEMENT

DATE: January 15, 1981

	<u>Item</u>	<u>Location</u>
<u>BEAVERHEAD COUNTY</u>		
Agreement Pending		
3F877	1966 Ward LaFrance Fire Truck	Wise River
<u>BIG HORN COUNTY</u>		
Agreement signed: 7-1-79		
3F817	1967 Kaiser Jeep with 200 gal. slip-on unit	Pryor
3F820	1968 Kaiser Jeep with 200 gal. slip-on unit 2- 5 man tool units	Lodge Grass
3F823	1967 Kaiser Jeep with 200 Gal. slip-on unit 1- 5 man tool unit	Hardin Hardin
<u>BROADWATER COUNTY</u>		
Agreement signed 9-11-72		
3F324	1961 International, 4x4, 6 passenger with 200 gal. slip-on unit	Toston
3F353	1952 Willys, 1/4 ton Jeep with 75 gal. slip-on unit, also 10 shovels, 10 Pulaskis, 10 headlamps	Winston VFD
3F460	1962 Dodge, 4x4, 6 passenger with 200 gal. slip-on unit 200 gal. slip-on unit with WA7 pump on county truck	Duck Creek Radersburg

	<u>Item</u>	<u>Location</u>
<u>BROADWATER COUNTY (Continued)</u>		
	1- 5 man tool unit	Duck Creek
	2- 10 man tool units	Duck Creek
3F736	1967 Kaiser Jeep with 200 gal. slip-on unit	Townsend
<u>CASCADE COUNTY</u>		
Agreement signed: 2-10-70		
3F382	1952 Willys, 1/4 ton Jeep with pumper	Neihart
3F433	1962 Dodge, 4x4, 6 passenger, with pumper pumper (county equipped)	P. Johnson Ranch E. of Cascade
3F419	1961 International, 4x4, 6 passenger with 200 gal. slip-on unit	S of Stockett Gasvoda Ranch
3F423	1964 Dodge 4x4, 6 passenger with 200 gal. slip-on unit (county equipped)	Misaro Ranch SE of Cascade
3F740	1968 Kaiser Jeep with 200 gal. slip-on unit	NE of Belt Ken Maki Ranch
3F432	1963 International, 1000 gal. tanker (county pump & tank)	Sand Coulee
	200 gal. slip-on unit, WA7 pump	Gibson Flats
	200 gal. slip-on unit, WGC4 pump	Montana Fire Training Service
3F760	1955 Dorsey Semi-van	" "
3F694	1961 Int. Trk Tractor	" "
	10 man tool unit	Cascade
	10 man tool unit	Sieben Livestock Ranch
	10 man tool unit	Vaughn
	10 man tool unit	Sun River
	10 man tool unit	Ft. Shaw
	10 man tool unit	Sand Coulee
	10 man tool unit	Black Eagle
	10 man tool unit	Sheriff's office Great Falls

Item

Location

10 man tool unit

Stockett

10 man tool unit

Belt

10 man tool unit

Ulm

CHOUTEAU COUNTY

Agreement signed: 7-13-70

3F208	¼ ton trailer with 10 man tool unit	Big Sandy
3F587	1964 Dodge, 4x4, 3 passenger with 200 gal. slip-on unit	Leo Faber Ranch
3F476	1962 Dodge, 4x4, 6 passenger with 200 gal. slip-on unit	Loma
3F654	1964 Dodge, 4x4, 3 passenger with 200 gal. slip-on unit	Carter
3F589	1965 Ford, 4x4, 3 passenger with 200 gal. slip-on unit	Highwood
3F710	1967 Kaiser Jeep with 200 gal. slip-on unit	Shonkin
3F748	1967 Kaiser Jeep with 200 gal. slip-on unit	Elim VFD Cecil Roddy Ranch
	10 man tool unit	Leo Fabor Ranch Big Sandy
	10 man tool unit	Loma
	10 man tool unit	Geraldine
	10 man tool unit	Carter
	2- 5 man tool units	Ft. Benton
	10 man tool unit	Highwood
	5 man tool unit	Shonkin VFD Floyd Zanto Ranch
	5 man tool unit	Shonkin VFD Al Rowe Ranch
3F793	1967 Kaiser Jeep with 200 gal. slip-on unit	Big Sandy

CUSTER COUNTY

Agreement signed: 7-1-79

3F796	1968 Kaiser Jeep with 200 gal. slip-on unit	Miles City
3F813	1968 Kaiser Jeep with 200 gal. slip-on unit	Kinsey

	<u>Item</u>	<u>Location</u>
3F852	1968 Kaiser Jeep with 200 gal. slip-on unit	Ismay
3F853	1967 Kaiser Jeep with 200 gal. slip-on unit	Deadmans Road
	1- 5 man tool unit	Ismay
	1- 5 man tool unit	Deadmans Road

DANIELS COUNTY

Agreement signed: 7-1-79

3F818	1967 Kaiser Jeep with 200 gal. slip-on unit	Peerless VFD Gary Leibrand Ranch
3F802	1967 Kaiser Jeep with 200 gal. slip-on unit	Whitetail VFD Scobey
3F854	1967 Kaiser Jeep with 200 gal. slip-on unit	Flaxville VFD
	10 man tool unit	Scobey
	County owned 1957 Reo 6x6 with State 1000 gal. slip-on unit	Scobey

DAWSON COUNTY

Agreement signed: 1-8-74

3F653	1964 Dodge, 4x4, 3 passenger with 200 gal. slip-on unit	Bud Stevenson Ranch
3F707	1967 Kaiser Jeep with 200 gal. slip-on unit	Don Moffet Ranch
3F777	1967 Kaiser Jeep with 200 gal. slip-on unit	Mahlsted Ranch
	1- 200 gal. slip-on unit	Stevenson Ranch
	2- 10 man tool units	County shops
	10 man tool unit	Lyle Perry Ranch
	10 man tool unit	Charles Casey Ranch

FALLON COUNTY

Agreement signed: 7-19-72

3F532	1968 Dodge, 4x4, 3 passenger with 200 gal. slip-on unit	McKay Ranch
3F472	¼ ton trailer with 10 man tool unit	Baker
3F651	1968 Dodge, 4x4, with 200 gal. slip-on unit	Merle Hayden Ranch

	<u>Item</u>	<u>Location</u>
3F529	1953 ¼ ton Jeep with 50 gallon slip-on unit	Pete Thielson Ranch
3F471	¼ ton trailer with 10 man tool unit	Plevna VFD
3F706	1968 Kaiser Jeep with 200 gal. slip-on unit	Neuman Ranch
3F779	1967 Kaiser jeep with 200 gal. slip-on unit	Baker FD
3F798	1967 Kaiser Jeep with 200 gal. slip-on unit	Baker FD
	200 gal. slip-on unit with WGC4 pump	Plevna FD
	10 man tool unit	Gorden Steen Ranch
	10 man tool unit	Ralph Tunby Ranch

GALLATIN COUNTY

Agreement signed: 11-14-69

3F343	1960 Ford, 1½ ton, 750 gal. tanker	Sourdough
3F401	1960 Ford, 1½ ton, 750 gal. tanker	Fort Ellis
3F403	1951 ¼ ton trailer with 10 man tool unit	Fort Ellis
3F473	¼ ton trailer with 10 man tool unit	Gallatin Gateway
3F113	1952 M-37 Dodge, 4x4, with 200 gal. slip-on unit	Pass Creek
3F656	1951 Reo, 6x6, pumper fire truck	Bridger Canyon
3F421	1953 Dodge, M-37 with 200 gal. slip-on unit	Sedan
3F404	¼ ton Jeep trailer with 10 man tool unit	Pass Creek
3F513	¼ ton Jeep trailer with 10 man tool unit	Sedan
3F482	1952 Diamond T with 1,000 gal. tanker	Maudlow
3F646	1962 International Boom Truck	Belgrade
3F715	1968 Kaiser Jeep with 200 gal. slip-on unit	Reese Creek
	10 man tool unit	Sedan
	10 man tool unit	Big Sky
	10 man tool unit	Maudlow
	10 man tool unit	Sourdough

	<u>Item</u>	<u>Location</u>
	10 man tool unit	Reese Creek
	10 man tool unit	Brackett Creek
	10 man tool unit	Bozeman (Gallatin County Law & Justice Center)

GLACIER COUNTY

Agreement signed:

3F508	1962 Ford, 4x4, with 750 gal. tanker	East Glacier
3F745	1965 Ward LaFrance Fire Truck	Chewing Block Bones Campground
	10 man tool unit	Cut Bank VFD
	10 man tool unit	East Glacier
	5 man tool unit	Chewing Block Bones Campground

GOLDEN VALLEY COUNTY

Agreement signed 7-23-73

3F573	1966 Dodge, 4x4, 6 passenger with 200 gal. slip-on unit	Mercer Ranch
3F689	1965 International 4x4, 6 passenger with 200 gal. slip-on unit	Lavina
3F643	1964 Dodge, 1 ton, Utility truck with 200 gal. slip-on unit	Erwin Allen Ranch Rygate
3F742	1967 Kaiser Jeep with 200 gal. slip-on unit	Paul Van Olmhauser Ranch- Barber
3F797	1967 Kaiser Jeep with 200 gal. slip-on unit	Rygate
	5 man tool unit	Erwin Allen Ranch
	5 man tool unit	Rygate
	5 man tool unit	Roy Patte Ranch
	10 man tool unit	Lavina



	<u>Item</u>	<u>Location</u>
<u>HILL COUNTY</u>		
Agreement signed: 7-13-70		
3F507	1963 Dodge, 4x4, 6 passenger with 200 gal. slip-on unit	Bear Paw VFD Sargent Ranch Clear Creek
3F522	¼ ton trailer with 10 man tool unit	Wildhorse VFD Joe Pruys Ranch N or Havre
3F649	1964 Dodge, 4x4, 6 passenger with 200 gal. slip-on unit	Wildhorse VFD Joe Pruys Ranch N of Havre
3F356	¼ ton trailer with 100 gal. pumper	Phalen Ranch
3F652	1960 International Boom Truck	Rudyard
3F708	1967 Kaiser Jeep with 200 gal. slip-on unit	Bearpaw VFD S of Havre Ed Molitor Ranch
	5 man tool unit	Bear Paw VFD Gregoire Ranch
3F747	1967 Kaiser Jeep with 200 gal. slip-on unit	Bear Paw VFD
	5 man tool unit	Bear Paw VFD Hingham
	10 man tool unit	Hill County Shop
	10 man tool unit	Kiwanis Camp
	5 man tool unit	Phalen Ranch
	200 gal. slip-on unit & 5 man tool unit	St. Joe VFD Henry Ver Ploegen Ranch
	5 man tool unit	Box Elder
	WGC4 pump & reel & 5 man tool unit	Fred Dusek Ranch
	5 man tool unit	St. Joe VFD
	5 man tool unit	Bear Paw VFD Ed Molitor Ranch
	5 man tool unit	Wildhorse VFD

Item

Location

JEFFERSON COUNTY

Agreement signed: 7-1-79

3F790	1968 Kaiser Jeep with 200 gal. slip-on unit	Whitehall
3F665	1952 Reo, 6x6, pumper fire truck	Elk Park
3F795	1967 Kaiser Jeep with 200 gal. slip-on unit	Boulder
3F816	1967 Kaiser Jeep with 200 gal. slip-on unit	Cardwell Whitehall
	10 man tool unit	Elk Park
	5 man tool unit	Whitehall
	5 man tool unit	Boulder
	5 man tool unit	Montana City VFD
	2 man tool unit	Warren Kiss Ranch

LEWIS & CLARK COUNTY

Agreement signed: 9-14-72

3F380	2½ ton Reo, 6x6, with 1000 gal. unit	Craig
3F486	1964 Dodge, 4x4, 6 passenger with 200 gal. slip-on unit	Lakeside
3F501	1961 International, 4x4, 6 passenger with 200 gal. slip-on unit	Ardo Nelson's Wolf Creek
3F647	1969 Dodge, 4x4, 6 passenger with 200 gal. slip-on unit	Canyon Creek
3F657	1952 International, 6x6, with 1000 gal. unit	Helena Sheriff's Office
3F714	1968 Kaiser Jeep with 200 gal. slip-on unit	Helena Sheriff's Office
	10 man tool unit	Lakeside
	2- 10 man tool units	Wolf Creek
	10 man tool unit	Augusta
	5 man tool unit	West Helena Valley VFD
	10 man tool unit	Birdseye
	5 man tool unit	Dearborn Ranch

	<u>Item</u>	<u>Location</u>
<u>LEWIS &amp; CLARK COUNTY (Cont.)</u>		
	5 man tool unit	Blacktail Ranch
	10 man tool unit	Canyon Creek
	2 man tool unit	MT. Fish, Wildlife and Parks
	10 man tool unit	Helena Sheriff's Office
<u>LIBERTY COUNTY</u>		
Agreement signed: 4-7-70		
3F506	1964 Dodge, 4x4, 6 passenger with 200 gal. slip-on unit	Bear Den VFD Defoe Ranch N or Chester
	5 man tool unit	Tiber Lake
	5 man tool unit	Orvil Brain Ranch
	5 man tool unit	Defoe Ranch
	5 man tool unit	Joplin
	10 man tool unit	Chester
	5 man tool unit	Demarest Ranch Witlash
<u>MEAGHER COUNTY</u>		
Agreement signed: 4-7-70		
3F484	1964 Dodge, 4x4, with 200 gal. slip-on unit	White Sulpher Springs
3F687	1968 Dodge, 4x4, with 200 gal. slip-on unit	Checkerboard
3F241	1967 1 ton trailer with 400 gal. pumper	Ringling
3F523	1953 M37 Dodge with 200 gal. slip-on unit	Fort Baker
3F642	1964 Dodge Utility, 4x4, with 200 gal. slip-on unit	Martinsdale
3F590	1965 Ford, 4x4, with 200 gal. slip-on unit	Fort Logan
3F588	1965 Ford, 4x4, with 200 gal. slip-on unit	Ringling
	10 man tool unit	Fort Baker
	10 man tool unit	Martinsdale

	<u>Item</u>	<u>Location</u>
<u>PARK COUNTY</u>		
Agreement signed: 11-25-70		
3F405	¼ ton trailer with partial 10 man tool unit	Livingston Rural VFD
3F521	¼ ton trailer with 10 man tool unit	Wilsall
3F449	1962 Chevrolet with 750 gal. pumper	Clyde Park
3F519	¼ ton trailer with 10 man tool unit	Springdale
3F737	1967 Kaiser Jeep with 200 gal. slip-on unit	Springdale
3F700	1967 Kaiser Jeep with 200 gal. slip-on unit	Emigrant
3F357	1/4 Ton Trailer with 100 gal. pumper	Emigrant (Larry Todd Ranch)
	200 gal. slip-on unit with WGC4 pump	Clyde Park
	200 gal. slip-on unit with WA7 pump	Wilsall
	10 man tool unit	Leffingwell Ranch Clyde Park
	10 man tool unit	Livingston Rural VFD Muir Hill Ranch
	10 man tool unit	Goat Mountain Wilsall
	10 man tool unit	S of Springdale
	10 man tool unit	Tom Miner Basin Emigrant
	Filler pump, XP72, Kohler engine	Emigrant

PONDERA COUNTY

Agreement signed: 12-15-70

3F422	1960 Ford, 1½ ton with 750 gal. tanker	Dupuyer
	500 gal. slip-on unit with WGC4 pump	E of Conrad
3F835	1967 Kaiser Jeep with 200 gal. slip-on unit	Brady
	3- 10 man tool units	Dupuyer
	5 man tool unit	Brady
	5 man tool unit	Valier

Item

Location

POWELL COUNTY

3F286 1952 International with 200 gal. slip-on unit Under separate agreement

PRAIRIE COUNTY

Agreement signed: 10-16-72

GMC, 6x6, with 1000 gal. pumper truck furnished by Cherry Creek  
Civil Defense, WGC4 pump, hose, reel, etc. furnished  
by Division of Forestry

3F463 ¼ ton trailer with 10 man tool unit Dave Strobel Ranch

3F686 1964 Dodge, 4x4, 6 passenger with 200 gal. slip-on unit Terry Grue Ranch

3F746 1967 Kaiser Jeep with 200 gal. slip-on unit Mathiason Ranch  
Mildred

200 gal. slip-on unit with WA7 pump Fallon FD

10 man tool unit Fallon FD

10 man tool unit Mathiason Ranch

10 man tool unit Roos Ranch

10 man tool unit Reukauf Ranch

3F799 1968 Kaiser Jeep with 200 gal. slip-on unit Grist Ranch

ROOSEVELT COUNTY

Agreement signed: 7-1-79

3F735 1967 Kaiser Jeep with 200 gal. slip-on unit E of Froid  
Duane Sundvold

3F814 1967 Kaiser Jeep with 200 gal. slip-on unit N of Poplar  
Mineral Bench

3F815 1967 Kaiser Jeep with 200 gal. slip-on unit N or Wolf Point  
Alvin Schaguman Ranch

3F834 1968 " " " " " " " " S of Bainville  
Mineral Ranch

3F832 1967 " " " " " " " " N of Wolf Point  
Bob Kauth Farm)

3F850 1967 " " " " " " " " NW of Culbertson  
B. Wolff Ranch

10 man tool unit N of Wolf Point

ItemLocationSILVERBOW COUNTY

Agreement signed: 4-13-70

3F446	1953 International with 1000 gal. tanker	Silverbow Airport
3F458	1964 Dodge, 4x4, 6 passenger with 200 gal. slip-on unit	Melrose
3F487	1964 Dodge, Utility, 4x4, with 200 gal. slip-on unit	Silverbow Airport

SWEET GRASS COUNTY

Agreement signed: 7-1-79

3F819	1968 Kaiser Jeep with 200 gal. slip-on unit	Big Timber
3F822	1967 Kaiser Jeep with 200 gal. slip-on unit	Melville
	2- 5 man tool units	
3F851	1967 Kaiser Jeep with 200 gal. slip-on unit	Reedpoint
	1- 5 man tool unit	Reedpoint

TETON COUNTY

Agreement signed:

3F741	1967 Kaiser Jeep with 200 gal. slip-on unit	Power
	500 gal. slip-on unit with WGC4 pump	Choteau
	200 gal. slip-on unit with WGC4 pump	Fairfield
	10 man tool unit	Fairfield
	10 man tool unit	Choteau
	5 man tool unit	Hutterite Colony West of Choteau

TOOLE COUNTY

Agreement signed: 11-25-70

3F152	1953 Dodge, M37, with 200 gal. slip-on unit	Ledger
3F618	1965 Ford, 4x4, 3 passenger with 200 gal. slip-on unit	Sunburst
3F794	1969 Kaiser Jeep with 200 gal. slip-on unit	Shelby
3F452	¼ ton trailer with 5 man tool unit	Shelby
	2- 5 man tool units	Shelby
	10 man tool unit	Sunburst

ItemLocationWHEATLAND COUNTY

Agreement signed: 7-9-69

3F325	1962 Dodge, 4x4, 6 passenger with 200 gal. slip-on unit	Judith Gap
3F660	1964 Dodge, 4x4, with 200 gal. slip-on unit	Shawmut
3F488	1964 Dodge, 4x4, 6 pass. with 200 gal. slip-on unit	Harlowtown
	200 gal. slip-on unit	Two Dot
	Portable Filler Pump	Harlowtown
	2- 10 man tool units	Harlowtown
	10 man tool unit	Two Dot
	10 man tool unit	Judith Gap
	5 man tool unit	Shawmut
	5 man tool unit	American Fork Ranch

YELLOWSTONE COUNTY

Agreement signed: 7-19-73

3F650	1964 Dodge, 4x4, 6 passenger with 200 gal. slip-on unit	Custer FD
3F504	1963 Dodge, 4x4, 6 passenger with 200 gal. slip-on unit	Shepherd FD
3F655	1966 Dodge, 4x4, 6 passenger with 200 gal. slip-on unit	Bar Diamond Ranch Unit #2
3F178	1953 Dodge, M-37, with 200 gal. slip-on unit	Talcott Ranch
3F505	1965 Dodge, 4x4, 6 passenger with 200 gal. slip-on unit	Worden FD
3F207	¼ ton trailer with 10 man tool unit	Don Warfield Ranch
3F744	1967 Kaiser Jeep with 200 gal. slip-on unit	Blue Creek Fire Dist.
3F762	¼ ton trailer (Burn out trailer)	SE Area Office
3F528	1962 International, 5 ton, truck tractor	SE Area Office
3F534	100 man fire cache van	SE Area Office
	200 gal. slip-on unit with WA7 pump	Yellowstone Boys Ranch

<u>Item</u>	<u>Location</u>
Pump with Wisconsin engine	Broadview FD
10 man tool unit	Laurel
10 man tool unit	High Duke Ranch
2- 10 man tool units	Shepherd VFD
10 man tool unit	Custer
10 man tool unit	Worden
10 man tool unit	P.K. Ranch
10 man tool unit	Broadview
10 man tool unit	Bar Diamond Ranch #2
10 man tool unit	Yellowstone Boys Ranch
10 man tool unit	Patterson Ranch
10 man tool unit	Mike Larrabee Residence
10 man tool unit	Gary Roam Residence
10 man tool unit	Schultz Ranch
10 man tool unit	Weldon Ranch
Partial tool unit	1122 Moon Valley Drive, Billings

II. Excess property in use by Missoula Rural Fire District under separate agreement:

3F431 1960 IHC Spray Cleaning Truck  
3F497 1954 Ward LeFranc Fire Truck

III. Excess property in use by East Missoula Fire Department under separate agreement:

3F693 1962 Dodge Van

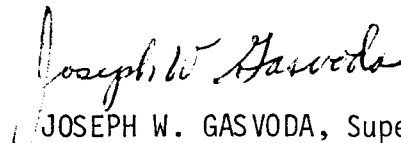
  
JOSEPH W. GASVODA, Supervisor  
Rural Fire Assistance Section  
Fire Management Bureau  
Division of Forestry

JWG:lg

cc: Brown, Peters, Ring, Pyke, Ahner,  
Roberts, Griffes, Kendall, C. Wright,  
Greene, Harrison, Underwood, Gragg, Roth, Dannenberg



# Proposed Funding Fire Program

Income                      State Accounts                      Expenditures

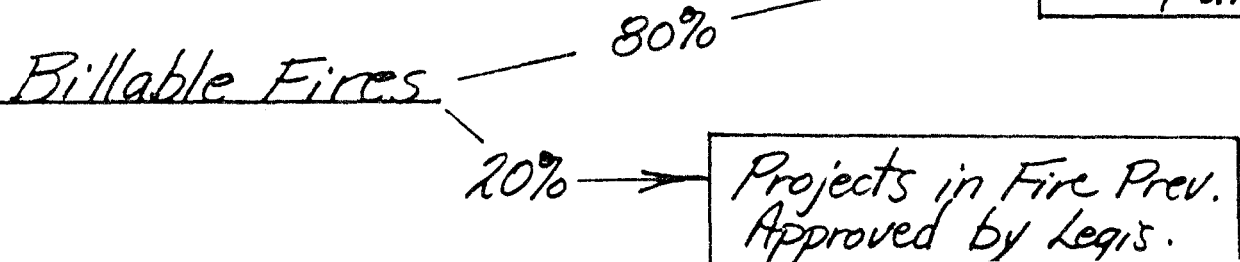
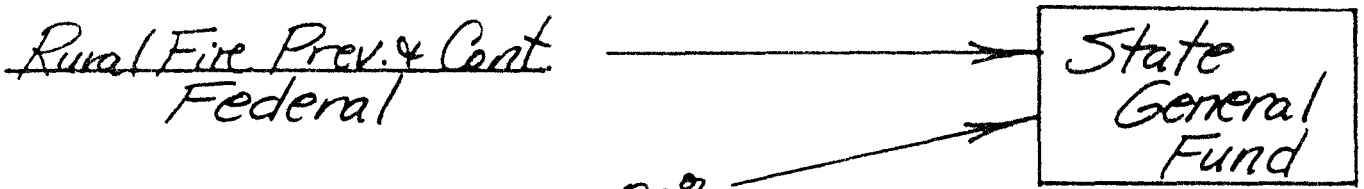
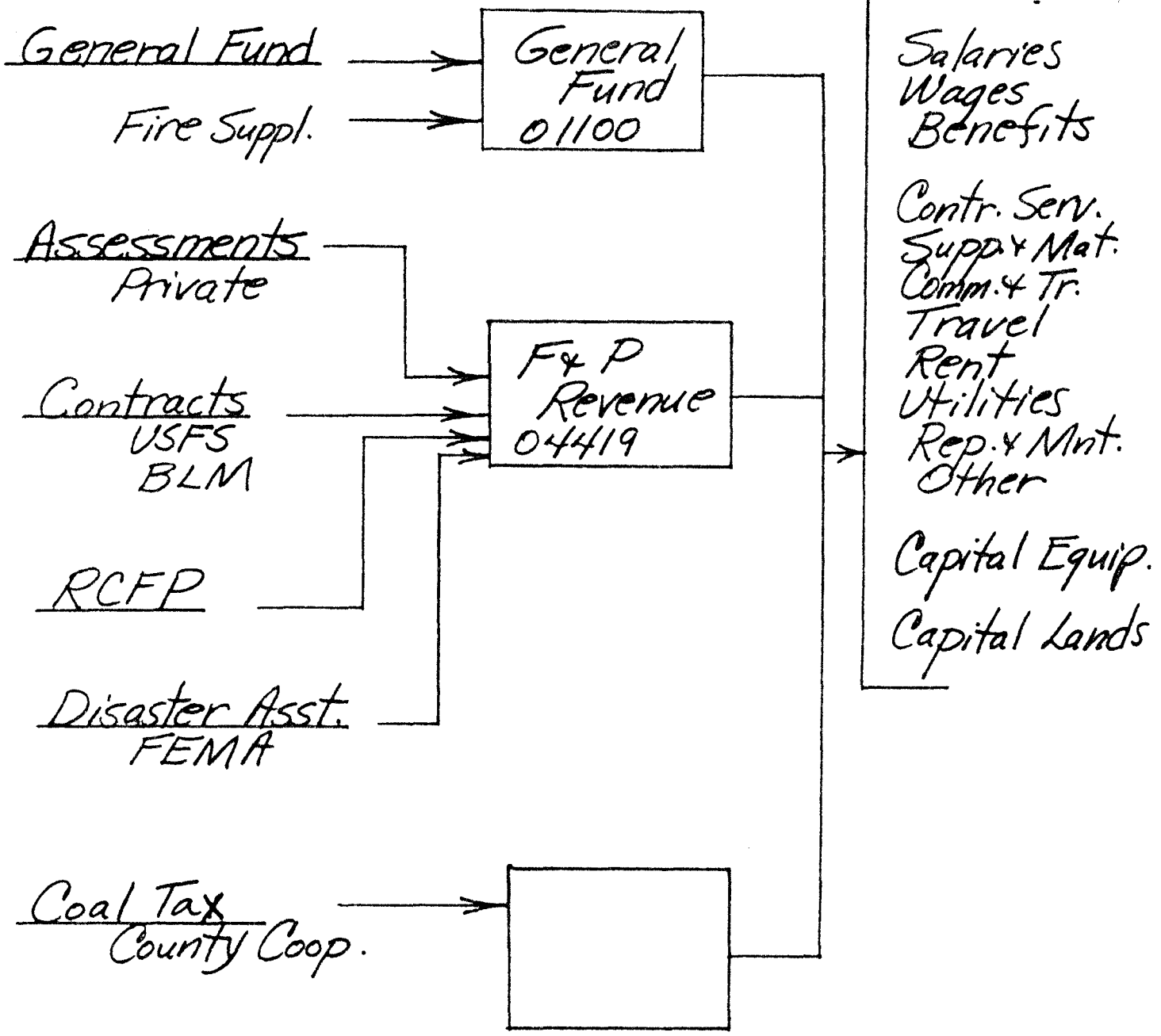



*The Big Sky Country*

## MONTANA STATE HOUSE OF REPRESENTATIVES

John M. Shontz  
District 53  
Capitol Station  
Helena, Montana 59620  
Route 1, Box 129A  
Sidney, Montana 59270

Patricia Cremer  
Legislative Aide

Committees:  
Appropriations,  
Highways & Transportation

February 5, 1981

Representative Chris Stobie, Chairman  
Appropriations Subcommittee on  
Natural Resources  
House of Representatives  
Capitol Building  
Helena, Montana 59620

Dear Representative Stobie:

Since another meeting precludes my presence this morning, I would ask the Subcommittee to consider adequately funding the rural fire program in Montana. The state's continued acquisition of surplus trucks and fitting them for fire fighting purposes is commendable.

Using local people as firefighters and having counties service the vehicles makes great sense when protecting state owned lands in Montana.

State lands subject to fire are widespread throughout Eastern Montana. This program assures fire protection for the lands at the lowest possible cost.

Thank you,

  
John M. Shontz

JMH/vk

**FIGURE II-A ENERGY RESOURCES AND FACILITIES OF MONTANA**

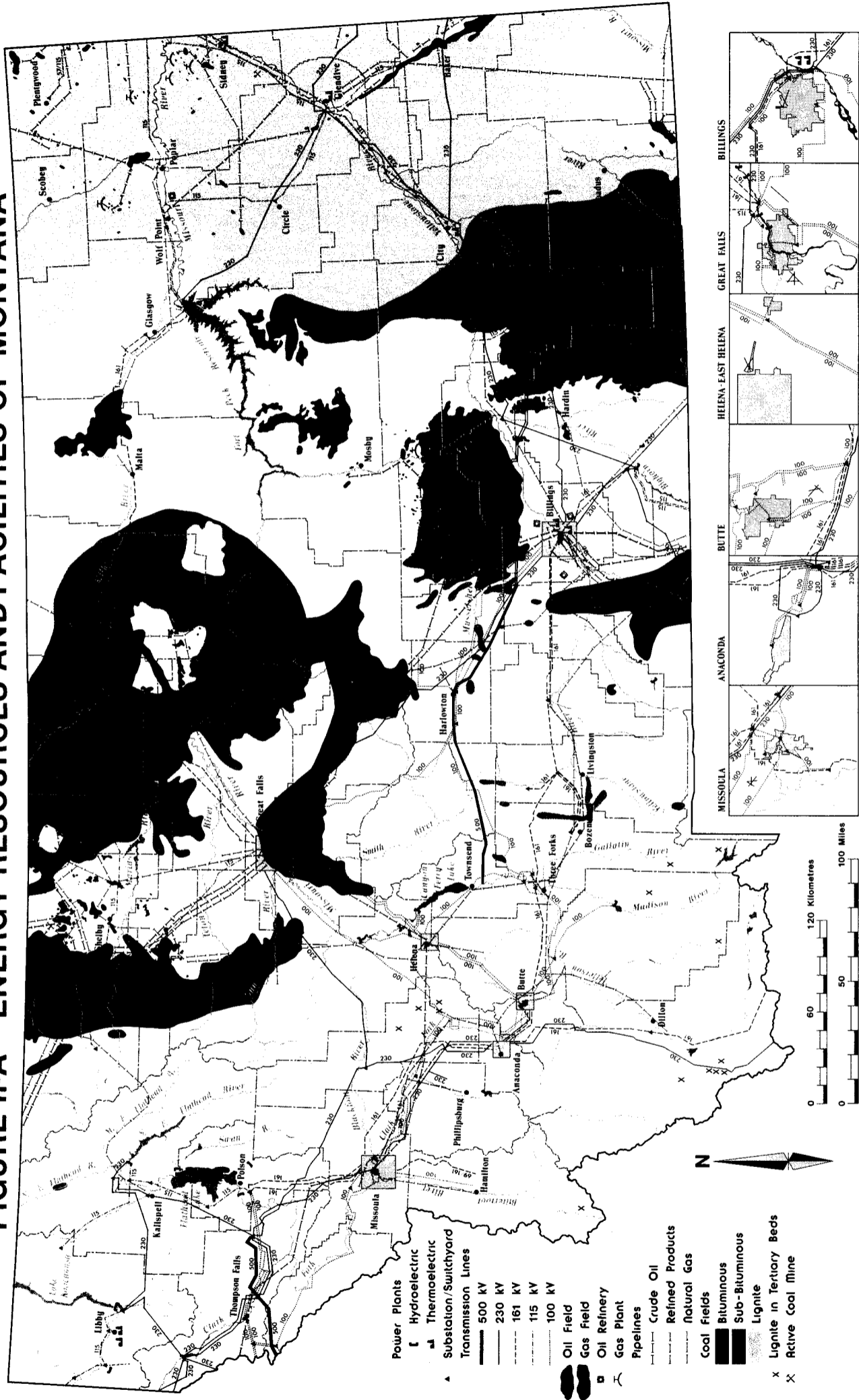

VISITORS' REGISTER

HOUSE

~~Forestry~~

COMMITTEE

JOINT APP. ON NATL Resources

ALL FORESTRY - DNR  
 REP. - U.S. interests in our forests 20-cuts

Date 2-6-81

NAME	RESIDENCE	REPRESENTING	SUPPORT	OPPOSE
Judy Rhoades	MT City	MCUFD	DO NOT cut FUNDS	
Will Kissinger	Mont. City	Mont City VFD	do not cut FUNDS	
Harvey Kattin BREF	Boulder	Boulder Rural Fire	Oppose to Cut	
Lorne Saligau	Elk Park	Elk Park VFD	Oppose cut	
Edith M. Paulock	Jefferson Co	Banning	oppose cut	
Tim Conice	Elk Park	Elk Park VFD	oppose cut	
Patricia Murphy	Elk Park	Elk Park VFD	opposing cut	
Marilyn Hall	Elk Park	Elk Park VFD	opposing cut	
Marie Skisland	Helena	MT Assoc. Co.	Oppose cut	
Tommy St. Rive	Elk Park	Elk Park VFD	opposing cut	
Lincoln Napier	Elk Park	Elk Park VFD	opposing cut	
Harry Brown	Missoula	DNR Division of Forestry	X	
David [unclear]	Missoula	DNR Division of Forestry	X	
Van Armstrong	Helena	DNR	X	
Earl Miller	Whitehall	Whitehall Vol	opposing cut	
Robert [unclear]	Butte Silver Bow	Butte	opposing cut	
Ed M. Catty	Butte Silver Bow	Butte	opposing cut	
Larry Ballard	Whitehall	Whitehall Vol.	opposing cut	
Walter Davis	Whitehall	Whitehall Vol	-	
Bill [unclear]	Big Timber	County Commission	opposing cut	
Kim Cook	Malville	Fire Chief	opposing cut	
James [unclear]	Big Timber	Fire Commission	opposing cut	
Deanne Rice	Big Timber	Fire Chief	opposing cut	

IF YOU CARE TO WRITE COMMENTS, ASK SECRETARY FOR LONGER FORM.

PLEASE LEAVE PREPARED STATEMENT WITH SECRETARY.

VISITORS' REGISTER

HOUSE JOINT APPROP SUB - COMMITTEE

NAT RES

FILE FORESTRY DIV - DNR

Date 2-6-81

SPONSOR

rep - witnesses - volunteer fire depts

NAME	RESIDENCE	REPRESENTING	SUPPORT	OPPOSE
<u>Robert G. Appell</u>	<u>Bozeman</u>	<u>Bozeman</u>	<u>✓</u>	
<u>Greg Fisher</u>	<u>Bozeman, Mont</u>	<u>Montana Vol Fire</u>	<u>✓</u>	
<u>Thomas R. Peterson</u>	<u>Bozeman</u>	<u>Bozeman</u>	<u>✓</u>	

IF YOU CARE TO WRITE COMMENTS, ASK SECRETARY FOR LONGER FORM.  
PLEASE LEAVE PREPARED STATEMENT WITH SECRETARY.